

# CNC machine

with servomotor drive

**FLATCom**<sup>®</sup>  
XL series



FlatCom XL with control panel

**isel**<sup>®</sup> France Des composants aux Systèmes

BP 41 - ZAC de la prévôté - 4 rue des côtes d'Orval - F-78550 - HOUDAN  
tel: +33(0) 130 461 201 fax: +33(0) 130 596 932 email: info@isel.fr

## Technical specification

	FLATCom <sup>®</sup> 102/72	FLATCom <sup>®</sup> 102/112	FLATCom <sup>®</sup> 142/112	FLATCom <sup>®</sup> 142/162	FLATCom <sup>®</sup> 142/252
Processing areas X/Y/Z [mm] *	1020/720/220	1020/1120/220	1420/1120/220	1420/1620/220	1420/2520/220
Clamping table surface W×D [mm]	1125 x 1300	1125 x 1700	1500 x 1700	1500 x 2200	1500 x 3050
Z-Throughput [mm]	235 (optional 435, in each case without processing unit)				
Dimensions W × D × H [mm]	2084/1584/1890	2084/1984/1890	2459/1984/1890	2459/2484/1890	2459/3384/1890
Processing speed X/Y/Z	appr. 250				
Repeatable accuracy [mm]	± 0,02				
Drive motors	48V servomotors				
Drive elements X/Y/Z	Recirculating ball drive, clearance free adjustable				
Controller	iMD CAN controller with 3 drive controllers, expandable to 12 axes (max. 6 interpolated & 6 handling axes), PC, I/O module, safety circuit with rest state monitoring, power supply unit 48V/1000 W				
Operation	19" CNC control panel with touchscreen, keyboard and mouse				
Weight [kg]	appr. 550	appr. 600	appr. 700	appr. 800	appr. 1000
Software	Windows, WinRemote (optional: ProNC, isy CAD-CAM)				
Connection values	400 V, 16 A				
Part no.	274552 0013	274553 0013	274554 0013	274555 0013	274556 0013

\* without mounted components on the axes.

# CNC machine

with servomotor drive

**FLATCom<sup>®</sup>**  
XL series

## General note

The choice of the ideal CNC machine for you should focus both on the clamping area for the workpiece, materials or plates to be machined and on the strategy or difficulties of the machining. In principal, all machines are perfectly suited to machining **light metals, non-ferrous metals, plastics and wood**. Extensive range of accessories for all our CNC machines to order. (see page E18 *et seq.*)

## Options

- PC control console with 2 free PCI plug-ins (for use by external PCI hardware)
- Safety light curtain
- toothed belt drive
- Milling and engraving spindles
- SK11/SK20 automatic tool change stations
- Minimum quantity lubrication or CoolMin cooling system
- Vacuum clamping benches
- Suction device
- 4. Axis e. g. RDH series installation
- Version without hood
- Maximum 6 interpolated axes + 6 handling axes
- Portal gap 300 mm
- closed hood attachment

## Setup

- Portal: mobile, bench: fixed

## Dimensioned drawings/dimensions

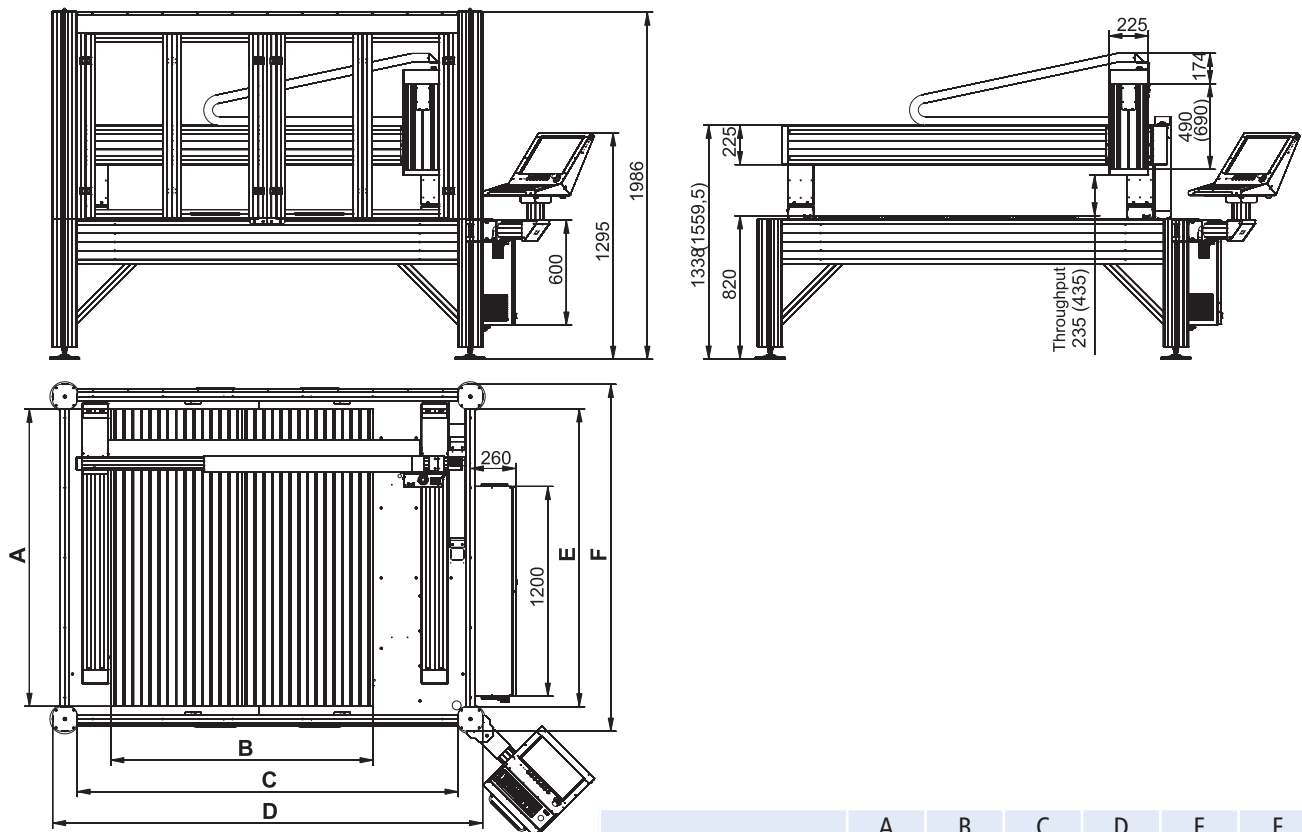

	A	B	C	D	E	F
FlatCom XL 102/72	1300	1125	1804	2084	1304	1584
FlatCom XL 102/112	1700	1125	1804	2084	1704	1984
FlatCom XL 142/112	1700	1500	2179	2459	1704	1984
FlatCom XL 142/162	2200	1500	2179	2459	2204	2484
FlatCom XL 142/252	3050	1500	2179	2459	3100	3380