

CNC machine

with servomotor drive

EUROMOD[®]
isel[®] France Des composants aux Systèmes

 BP 41 - ZAC de la prévôté - 4 rue des côtes d'Orval - F-78550 - HOUDAN
 tel: +33(0) 130 461 201 fax: +33(0) 130 596 932 email: info@isel.fr

EuroMod MP 30 with closed sliding door

Technical specification

	<i>EUROMOD</i> [®] MP 30	<i>EUROMOD</i> [®] MP 45	<i>EUROMOD</i> [®] MP 65
Traversal path X/Y/Z [mm]	650/300/250	650/450/250	1000/650/250
Clamping table surface W×D [mm]	900x350	900x500	1200x700
Throughput [mm]	350		
Dimensions W × D × H [mm]	1160x800x1700	1160x1110x1700	1480x1510x1700
Processing speed X/Y/Z	appr. 250 mm/s		
Repeatability [mm]	± 0,02		
Drive motors	48V servomotors		
Drive elements X/Y/Z	Recirculating ball drive, clearance free adjustable		
Controller	iMD CAN controller with 3 drive controllers, expandable to 12 axes (max. 6 interpolated & 6 handling axes), PC, I/O module, safety circuit with rest state monitoring, power supply unit 48V/1000 W		
Operation	19" CNC control panel with touch screen, keyboard and mouse		
Weight [kg]	appr. 250	appr. 280	appr. 375
Software	Windows, WinRemote (optional: ProNC, isy 2.5 PLUS)		
Connection values	230V, 16A		
Part no.	275133 33665	275143 33665	275153 33665

* without mounted components on the axes.

CNC machine

with servomotor drive

EUROMOD[®]

General note

The choice of the ideal CNC machine for you should focus both on the clamping area for the workpiece, materials or plates to be machined and on the strategy or difficulties of the machining. In principal, all machines are perfectly suited for machining light metals, non-ferrous metals, plastics and wood. Extensive range of accessories for all our CNC machines to order (see page E18 et seq.).

Options

- PC control console with 2 free PCI plug-ins (for use by external PCI hardware)
- Stainless steel keyboard
- Safety light curtain
- Milling and engraving spindles
- SK11/SK20 automatic tool change stations
- Minimum quantity lubrication or CoolMin cooling system
- Vacuum clamping benches
- Suction device
- 4. Axis e. g. RDH series installation
- pneumatic sliding door
- closed hood attachment

Setup

- Portal: fixed, bench: mobile

Dimensioned drawings/dimensions

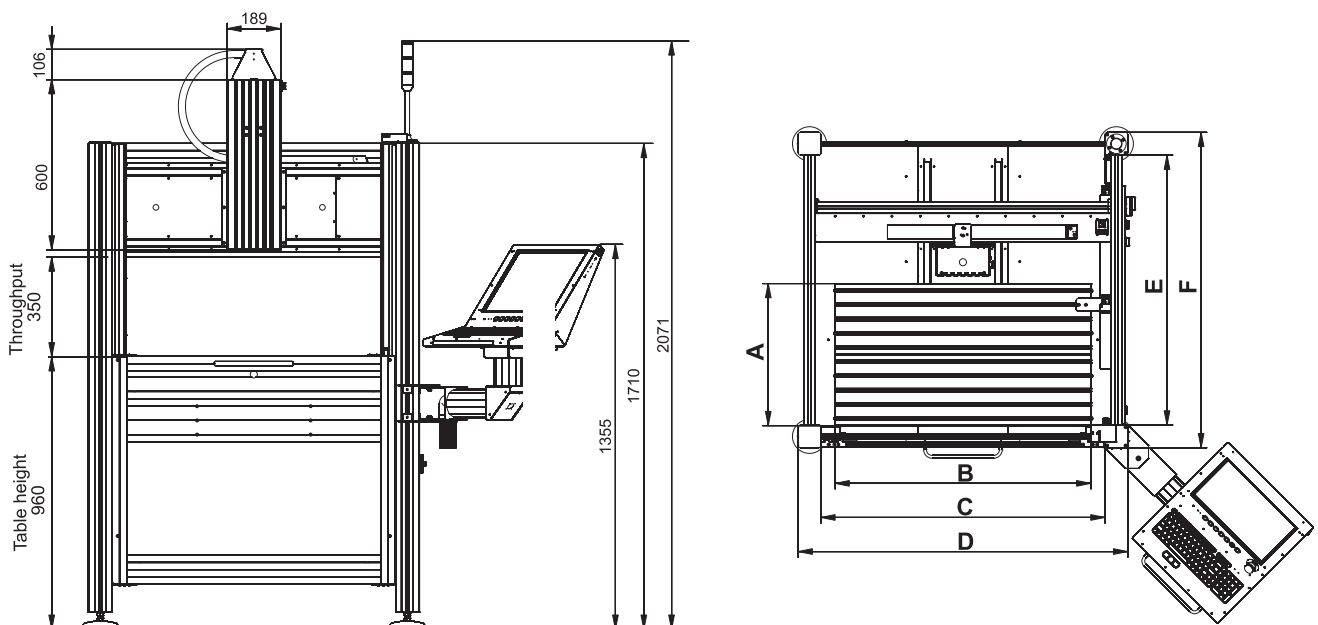

	A	B	C	D	E	F
EuroMod MP30	350	900	1000	1160	640	800
EuroMod MP45	500	900	1000	1160	950	1110
EuroMod MP65	700	1200	1200	1480	1350	1510

Technical specifications subject to change.